

3200XL Auto Close Not Working

If the auto close timer is not automatically closing the gate, try the following:

1. Check to see that the auto close timer is turned ON.

Auto Close

The 'AUTO CLOSE TIME' pot controls auto close feature.

Turning the pot all the way counter-clockwise will turn auto close feature off. The minimum auto close time is 3 seconds. The maximum (turn the pot all the way clockwise) auto close time is 120 seconds.

Auto Close Time Pot

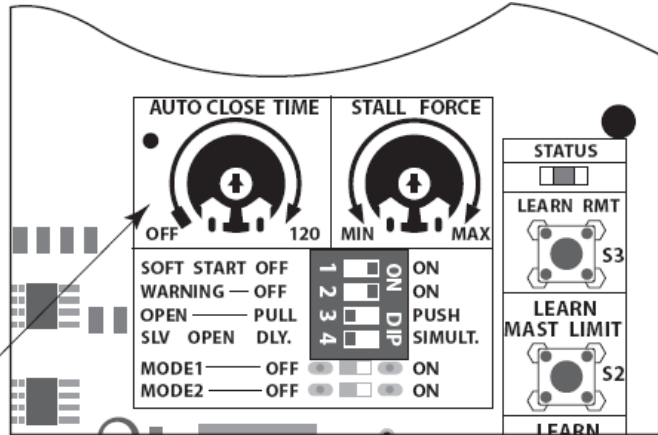

2. Check to ensure that the #3 dip switch is set correctly for Pull to Open applications.

DIP Switch #3 - Push/Pull-to-Open

ON - Push to open.

OFF - Pull to open (factory preset).

If your gate opens into the property the DIP Switch is set to the OFF position (factory setting). If your gate opens out from the property the DIP Switch must be set to the ON position.

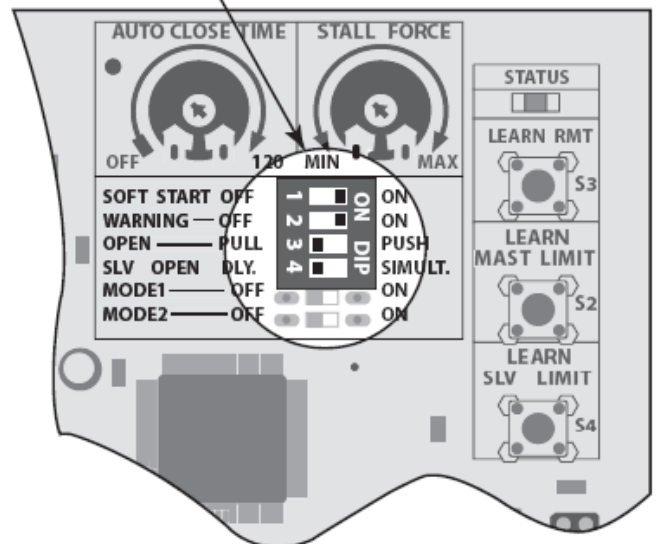
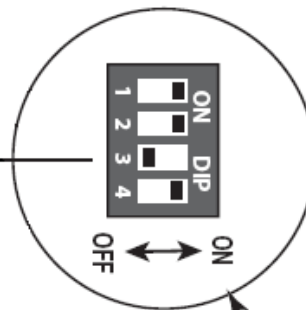

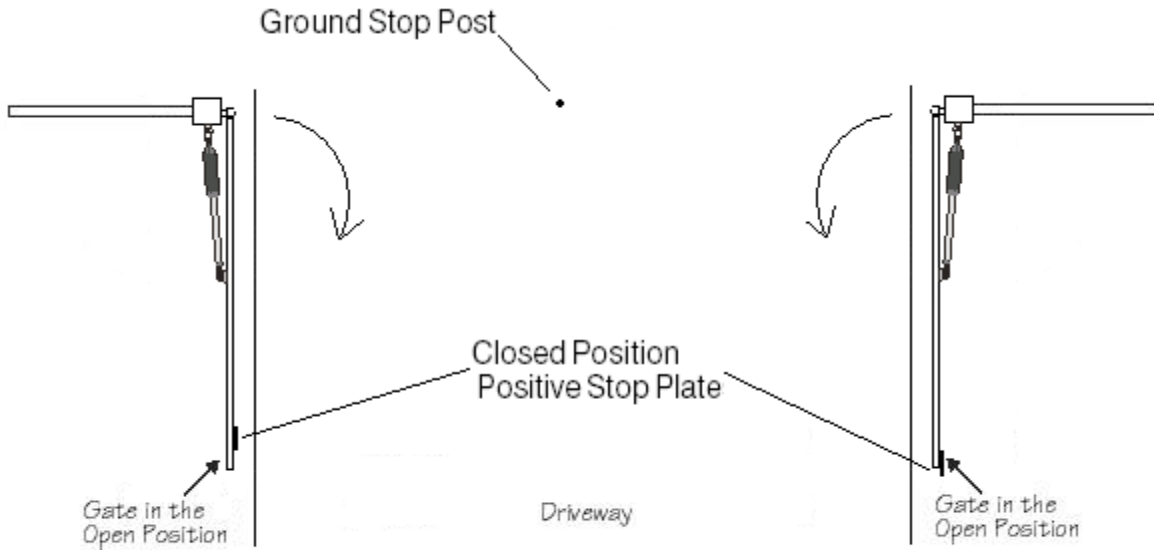

If the gate opens into the property as shown, it is a pull to open gate.

3. Check the adjustment of the gate bracket in the middle of the gates.

Disconnect the arm from the gate.

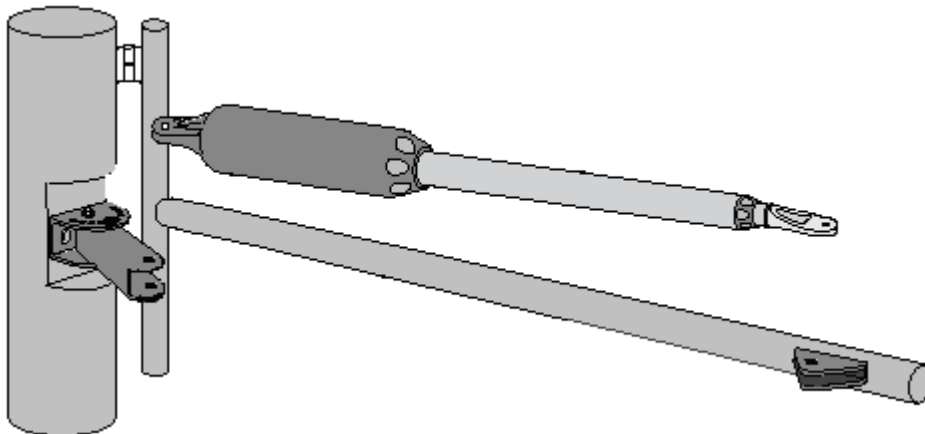

Use the remote or push button to retract the tubes.

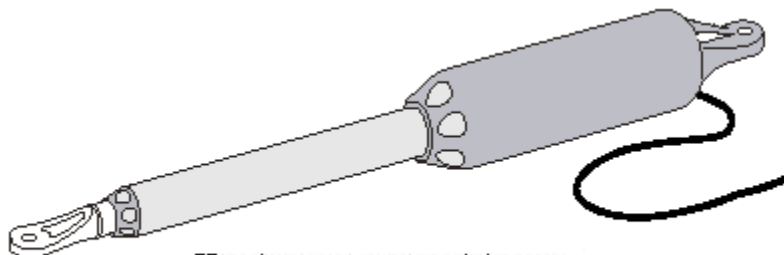

Use the remote or push button to fully retract the operator arm.

Try mounting the arms on the gates with the push/pull tube fully retracted and the gates in the open position. If the clevis pins will not line up with the holes in the gate bracket, you will need to readjust the gate bracket in the middle of the gate to the operator arm.

